

SAFE-T-DRIFT

Top View

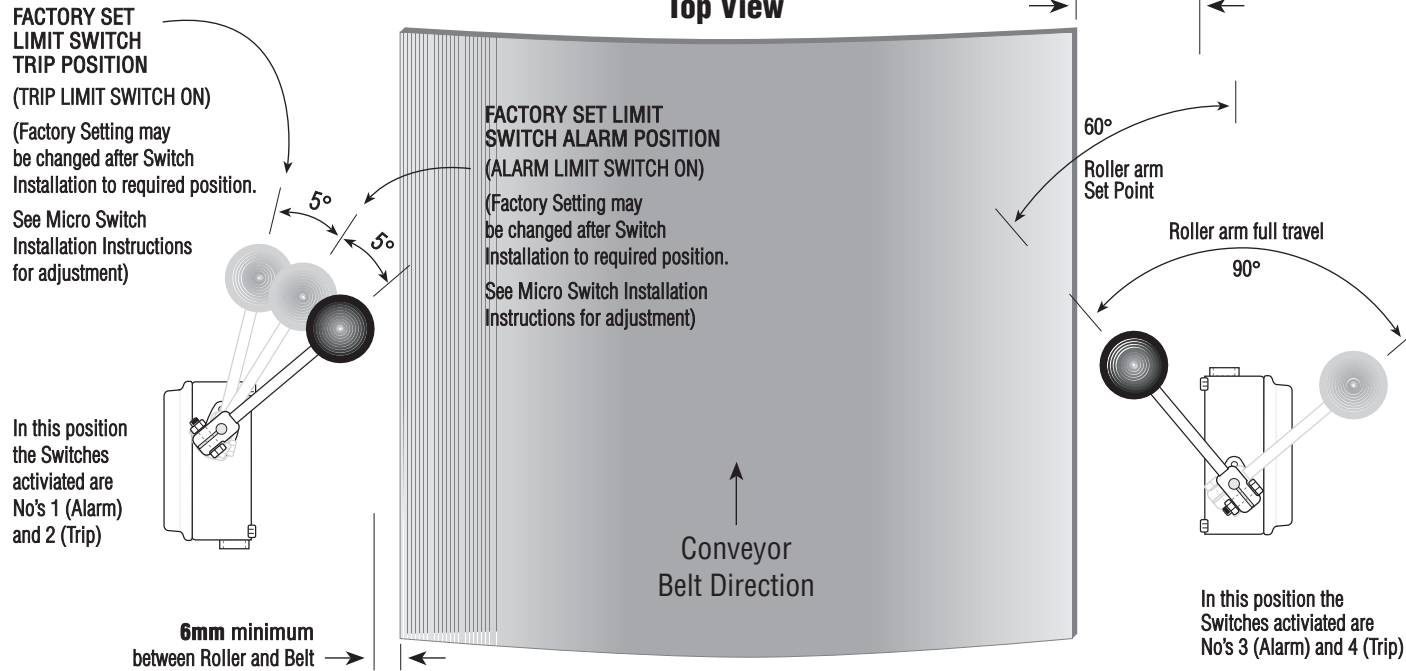

Limit switch trip position to be set anywhere before the Conveyor Belt rides over the top of the roller.

STD-HA ARM, SHOWN

MATERIAL ZONE

STD-HASR ARM, SHOWN

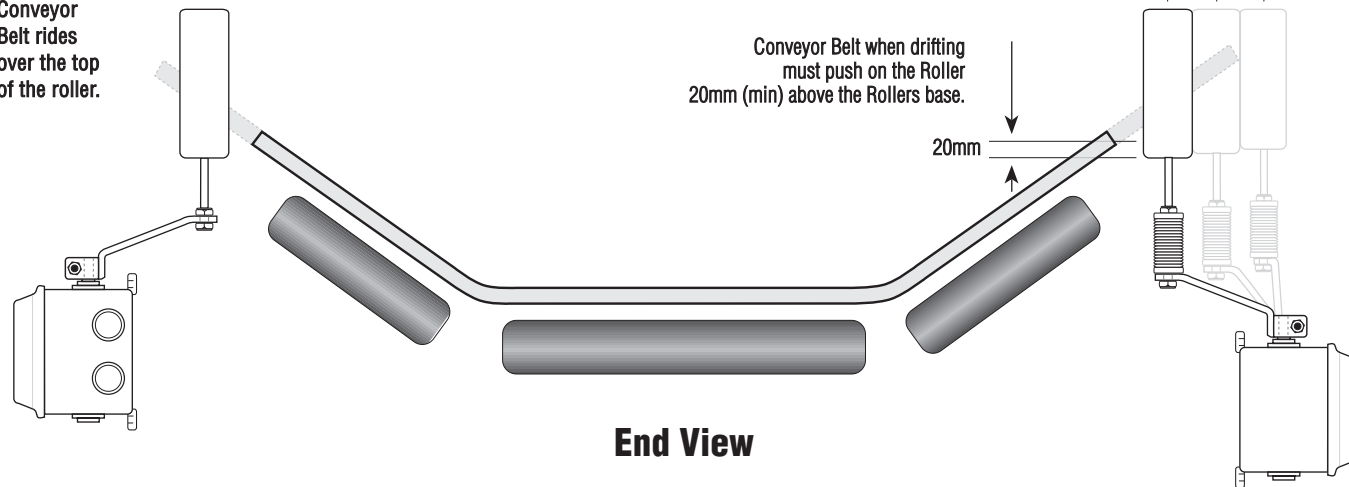

HORIZONTAL ARM

Part No's: STD-HA; STD-HASR;

Installation Instructions

HA Rollers are used for large items on conveyor

Recommended Belt Drifts to use with STD-HA / HASR

Part No's: STD-P-D/-? STD-P-D-K/-?

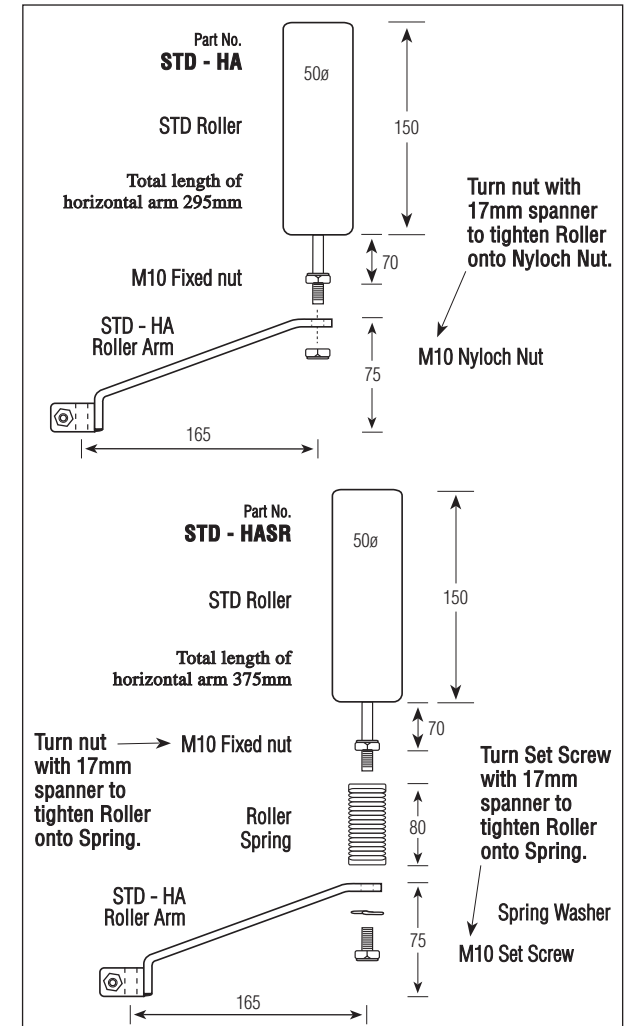

Telephone:
(08) 9249 1044

Made in Australia Pub No. HA 804

CE Conformity

Electric Control PRODUCTS

Pub No. DEL 027 05/06